

POZNAMKA 1
MIERKA 1:1

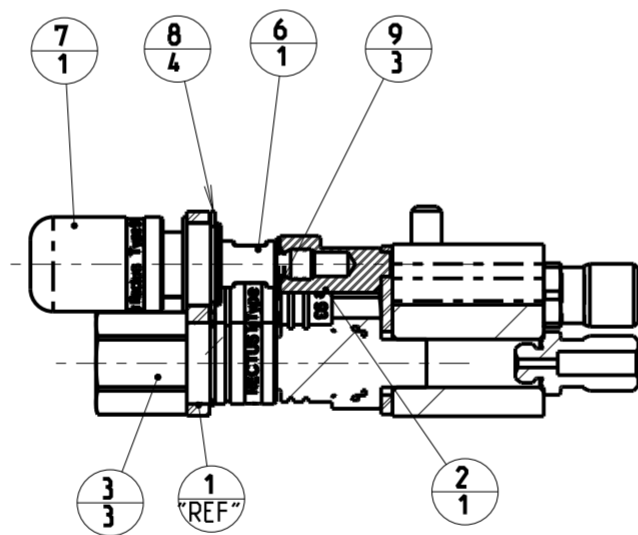

REZ A-A

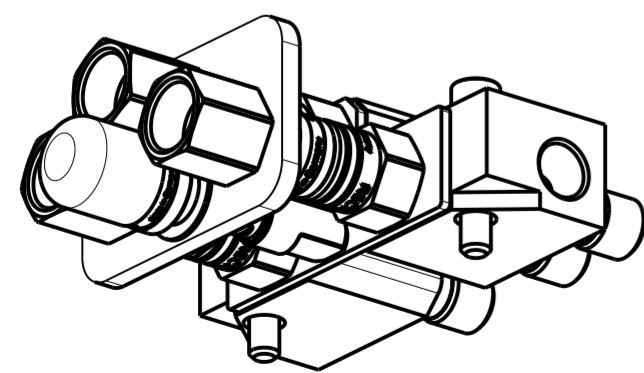

3D POHLAD
MIERKA 1:2

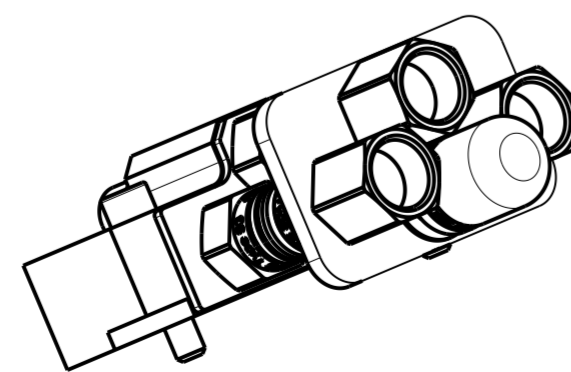

3D POHLAD 2
MIERKA 1:2

9	PODLOZKA 0_3_MM_8X14		3
8	POISTNY KRUZOK 21		4
7	SPOJKA		1
6	KOLIK		1
5	SPOJKA 3/8		1
4	SPOJKA 1/2		2
3	SPOJKA		3
2	KONZOLA ZVARENEC		1
1	KONZOLA		1

POL.	NAZOV KOMPONENTU	OZNACENIE KOMPONENTU - NORMA - VYROBNE OZNACENIE	KS
------	------------------	--	----

METODA PREMIEŤANIA	⊕	MIERKA	1:2	SYMBOL	REVIZIA	DATUM	PODPIS
PROJEKT	SPOJKA 4						
VSEOB. TOL.				CEHY			
MATERIAL 1	VID DETAILY						
MATERIAL 2	MATERIAL 3			NAZOV KOMPONENTU SPOJKA 4			
HMOTNOST	2.14 kg			CISLO KOMPONENTU CHA00086			
KRESLIL	ING. KAROL RAFFAY			LIST C. POCET LISTOV 1 1			
RODIC. ZOSTAVA							
FORMAT	A2	DATUM	170504				